



**Visian ICL™ (Implantable Collamer Lens)  
For Nearsightedness**

**Facts You Need To Know About STAAR Surgical's Visian ICL  
SURGERY**

**PATIENT INFORMATION BOOKLET**

**For Nearsightedness (Myopia) between -3 to -20 Diopters  
with 2.5 Diopters or less of Astigmatism**

**Please read this entire booklet. Discuss its contents with your eye doctor so that you have all of your questions answered to your satisfaction. Ask any questions you may have before you agree to this surgery.**

**Distributed by:  
STAAR Surgical Company  
1911 Walker Avenue  
Monrovia, CA 91016 USA  
Tel: (800) 352-7842  
FAX: (800) 952-4923**

**Manufactured by:  
STAAR Surgical, AG  
Hauptstrasse 104  
CH-2560 Nidau, Switzerland  
Tel: + (41) 32 332 8888  
FAX: + (41) 32 332 8899**

**Copyright 2006 by STAAR Surgical Company**

**This booklet may be reproduced only by a treating physician, for use with patients considering Visian ICL Surgery. All other rights are reserved.**

**This page left blank intentionally.**

## TABLE OF CONTENTS

1.0 Introduction.....	3
2.0 How Does VISIAN ICL Correct NEARSIGHTEDNESS?.....	3
3.0 What Are the Benefits of THE VISIAN ICL for NEARSIGHTEDNESS? .....	6
4.0 What Are the Risks of THE VISIAN ICL for NEARSIGHTEDNESS?.....	9
5.0 ALTERNATIVE TREATMENTS .....	10
6.0 Contraindications .....	11
7.0 Warnings.....	11
8.0 Precautions.....	12
9.0 Are You a Good Candidate for VISIAN ICL for NEARSIGHTEDNESS Surgery? .	13
10.0 What Should You Expect During VISIAN ICL Surgery?.....	14
11.0 Questions To Ask Your Doctor .....	16
12.0 Self-Test.....	18
13.0 Summary of Important Information.....	19
14.0 GLOSSARY .....	20
15.0 Patient Assistance Information .....	27

## 1.0 INTRODUCTION

The purpose of this booklet is to provide you with information on the *Visian ICL* surgery for *nearsightedness (myopia)*. Please read this entire booklet carefully. See the “Glossary” (Section 14) for an explanation of words shown in *italics*. Discuss your questions with a doctor trained in *Visian ICL* surgery. You need to understand the benefits and risks of this surgery before making a decision to have this procedure.

You may have *nearsightedness* if you have trouble seeing objects clearly when they are far away. *Nearsightedness*, which is also called *myopia*, is a type of condition that causes blurred vision. Glasses, contact lenses or eye surgery can correct *nearsightedness* and help you see distant objects more clearly.

Your eyeglass prescription is the usual way to tell how *nearsighted* you are. Your doctor will use your eyeglass prescription with a thorough eye examination to determine if you are a candidate for *Visian ICL* surgery. Discuss with your doctor whether you are a good candidate for *Visian ICL* surgery.

*Visian ICL* surgery is permanent as long as the *Visian ICL* stays in your eye. The *Visian ICL* can be removed or replaced at a future date. However, the residual effect of the *Visian ICL* on your eye after it is removed or replaced is not known.

## 2.0 HOW DOES VISIAN ICL CORRECT NEARSIGHTEDNESS?

You see objects because your eye focuses light into images. Your eye works like a camera. The camera lens focuses light to form clear images onto film. Both the *cornea* and *lens* in the eye focus light onto the back surface of the eye, called the *retina*. Diagram 1 shows that distant vision is clear when light focuses correctly.

### DIAGRAM 1: NORMAL EYE

Light focuses on the retina.  
Vision is clear.

#### Normal Eye

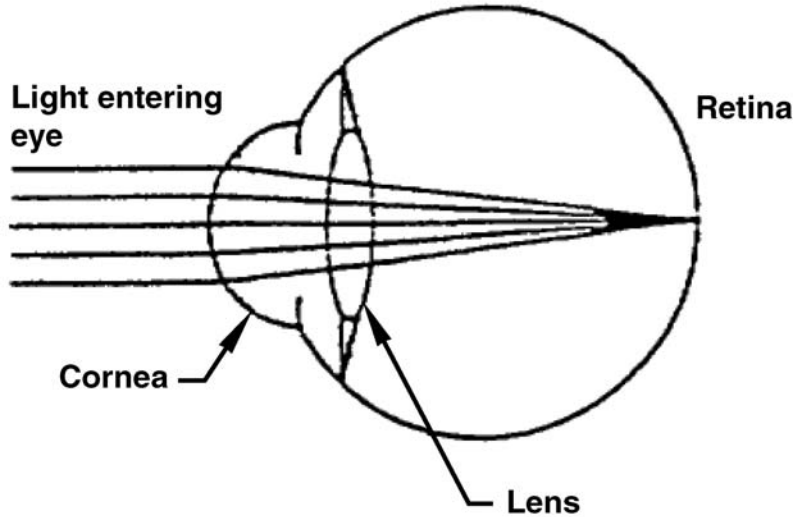

*Nearsightedness* is a type of focusing error that results in blurry distant vision. Light from a distant object focuses in front of the *retina*, rather than on the *retina*. Diagram 2 shows that distance vision is blurry when light focuses incorrectly in a *nearsighted* eye.

### DIAGRAM 2: NEARSIGHTED EYE

Light focuses in front of the retina.  
Vision is blurry.

#### Nearsighted Eye

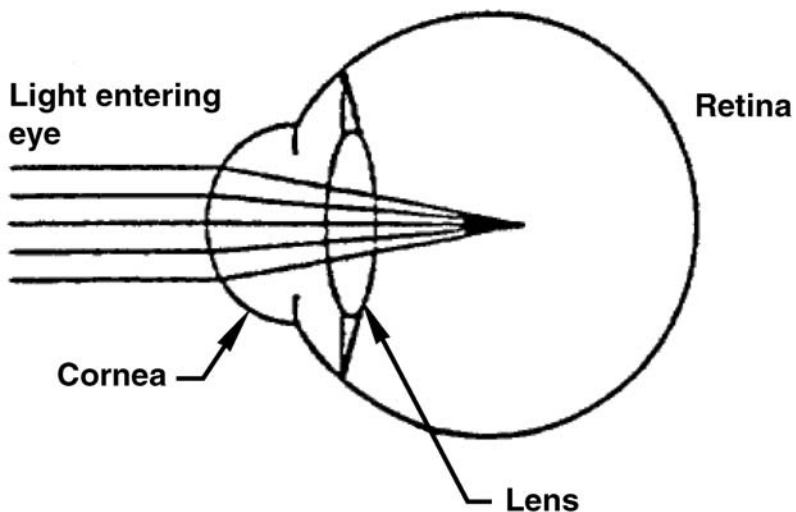

Wearing glasses and contact lenses help your eye focus light properly on the *retina*.

The *Visian ICL* is placed entirely within the *posterior chamber* (back chamber of the eye) directly behind the *iris* and in front of the *anterior capsule* (front surface) of the *crystalline lens* (*lens in eye*). When correctly positioned, the *Visian ICL* functions to focus light properly on the *retina*.

Diagram 3 shows that distant vision is clearer after *Visian ICL* surgery.

### DIAGRAM 3: CORRECTION OF VISION AFTER VISIAN ICL SURGERY

Light focuses on the retina after surgery.  
Vision is clearer.

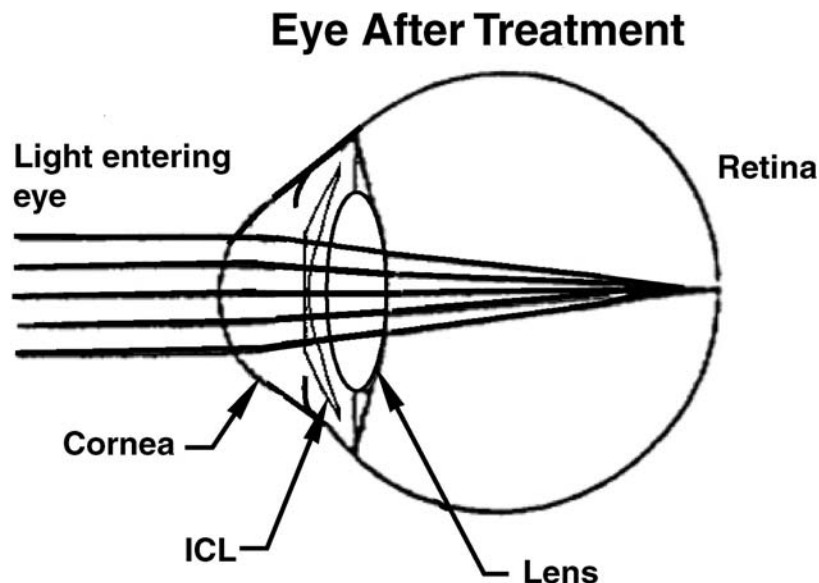

The *Visian ICL* is made from a soft plastic and *collagen*-based material called Collamer® with a design similar to existing *intraocular lenses* currently used to correct vision after *cataract* surgery. The *Visian ICL* is placed through a small incision in your eye, in front of your existing *crystalline lens* in your eye to improve your *nearsightedness*.

The *Visian ICL* is designed for the correction of moderate to high *nearsightedness*. It is not intended to correct any *astigmatism* you may or may not have. *Astigmatism* as seen

below is a focusing error of the eye that results in blurred vision. In eye with astigmatism, *cornea* is more curved in some directions than others. This causes light rays to focus at different points inside the eye. Therefore, some parts of objects appear clearer than other parts.

**DIAGRAM 4: NEARSIGHTED and ASTIGMATIC EYE**

### **Nearsighted and Astigmatic Eye**

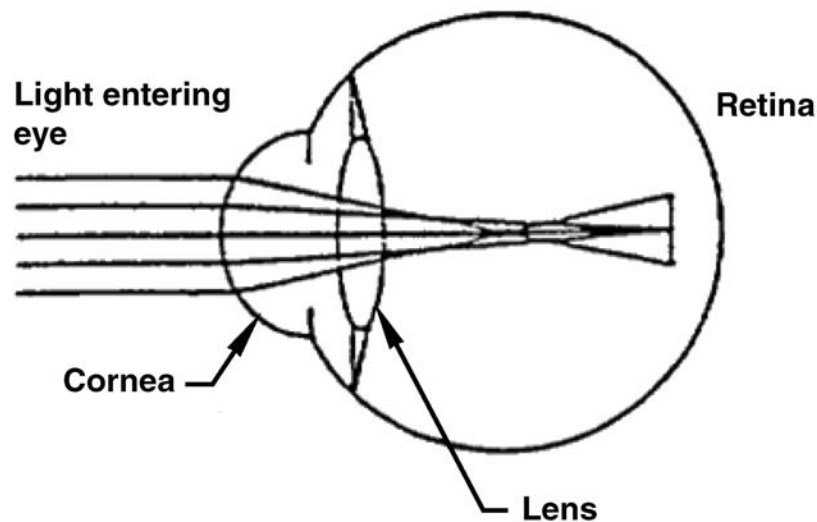

### **3.0 WHAT ARE THE BENEFITS OF THE VISIAN ICL FOR NEARSIGHTEDNESS?**

*Visian ICL* surgery has been documented to safely and effectively correct *nearsightedness* between  $-3$  diopters (D) to  $-15$  diopters (D), and partially correct *nearsightedness* up to  $-20$  diopters in eyes with up to  $2.5$  diopters (D) of *astigmatism*. If you have *nearsightedness* within these ranges, *Visian ICL* surgery may improve your distance vision without eyeglasses or contact lenses.

#### **Clinical Study to Evaluate Risks and Benefits of the Visian ICL:**

A clinical study was conducted to evaluate the benefits and risks of *Visian ICL* Surgery. The study included 526 eyes of 294 patients to determine benefits and risks. The study

results are discussed below and in “What are the Risks of the Visian ICL for Nearsightedness?” (Section 4).

- **Description of Study Patient Group:**

- Most patients were Caucasian. Patients in the study ranged in age from 21 to 45 years of age and over half of the patients were female.
- Nearsightedness before surgery ranged between –3.00D and –20.00D. The average was –10.06D.

- **Visual Acuity *without* Glasses after Surgery:**

- Visual acuity measures the sharpness of vision using a letter chart. In most states in the U.S. 20/40 or better vision is required to drive a car without glasses or contact lenses. Three years after insertion of the Visian ICL, 94.7% of eyes in the Visian ICL study saw 20/40 or better without glasses or contact lenses.

**Visual Acuity\* by Preoperative Myopia**

<b><u>Lens Group</u></b>	<b>Exam Interval</b>	<b>20/20 or Better</b>	<b>20/40 or Better</b>
<b>Study Patients</b>	1 Year	65.4%	96.7%
	2 Year	59.6%	93.4%
	3 Year	59.3%	94.7%
<b>Myopia Subgroup</b>			
<b>≤ -7 D</b>	1 Year	76.3%	98.8%
	2 Year	70.3%	97.3%
	3 Year	72.4%	98.3%
<b>&gt; -7 D to -10 D</b>	1 Year	70.0%	96.0%
	2 Year	64.3%	94.9%
	3 Year	62.7%	92.8%
<b>&gt; -10 D to -15 D</b>	1 Year	43.3%	93.7%
	2 Year	37.5%	95.0%
	3 Year	37.5%	93.8%
<b>&gt; -15 D</b>	1 Year	NA%**	NA%**
	2 Year	NA%**	NA%**
	3 Year	NA%**	NA%**

\*Eyes with Preoperative Vision with glasses 20/20 or Better and Targeted for Complete Correction

\*\* No Eyes > -15 D group with this Preoperative Vision or Targeted Correction



In the clinical study of the *Visian ICL*, vision **without** glasses improved for all eyes except in those eyes with the most extreme amount of *nearsightedness* that the strongest *Visian ICL* could not completely correct and 1 case that developed a *retinal detachment* where the uncorrected vision remained unchanged. Some people still needed glasses or contact lenses after surgery to view distant objects .

### **Patient Satisfaction after Visian ICL Surgery:**

Patients were asked to report their satisfaction with the *Visian ICL* procedure. Three years after *Visian ICL* surgery, 92.1% of patients were very/extremely satisfied and 7.3% were moderately/fairly satisfied with their vision. Only 0.6% of cases were unsatisfied.

### **Quality of Vision after Visian ICL Surgery:**

Quality of vision reported by patients as very good/excellent improved from 55% before the *Visian ICL* to 77% 3 years after the *Visian ICL* procedure. Patients reporting poor/very poor vision dropped in half at 3 years (5.8%) compared to before the *Visian ICL* (11.6%).

Patients were asked on a questionnaire to report on the following symptoms before and 3 years after the *Visian ICL* procedure. More patients rated the following symptoms absent or mild at 3 years compared to before the *Visian ICL*: *glare*, night vision difficulties and night driving difficulties. *Halos* and double vision percentages were similar before the *Visian ICL* and at 3 years.

The higher the level of nearsightedness before the *Visian ICL* procedure, the more frequent and more severe these symptoms were reported both before and after the *Visian ICL* procedure.

### Subjective Patient Symptoms- Compared to Pre-op

Patient Symptom	Improved at 3 Years	No Change at 3 years	Worsened at 3 Years
Glare	12.0%	78.3%	9.7%
Halos	9.1%	79.4%	11.4%
Double Vision	1.1%	97.2%	1.7%
Night Vision	12.0%	76.0%	12.0%
Night Driving Difficulties	13.7%	76.1%	10.1%

#### 4.0 WHAT ARE THE RISKS OF THE VISIAN ICL FOR NEARSIGHTEDNESS?

**Implantation of the Visian ICL is a surgical procedure, and as such, carries potentially serious risks. Please review this brochure and discuss the risks with your ophthalmologists.**

- **First Week after Visian ICL Surgery:** complications reported included: *Visian ICL* removal and reinsertions (2.5%), *shallowness of the front chamber of the eye* (0.4%), need for *peripheral iridectomy* (0.2%), temporary *corneal swelling* (edema, 11.4%) and transient inflammation in the eye or *iritis* (19.5%).
  
- **Complications After 1st Week:** increase in *astigmatism* (0.4%), loss of *best corrected vision* (1.9%), clouding of the *crystalline lens* (*cataract*, 1.4%), loss of cells from the back surface of the cornea responsible for the cornea remaining clear (*endothelial cell loss*, 8.9% at 3 years), increase in eye pressure (0.4%), *iris prolapse* (0.2%), cloudy areas on the *crystalline lens* that may or may not cause patient symptoms (*lens opacities*, 2.7%), *macular hemorrhage* (0.2%), *retinal detachment* (0.6%), secondary *Visian ICL* related surgeries (replacements, repositionings, removals, removals with *cataract* extraction, 3.1%), *subretinal hemorrhage* (0.2%), too much or too little *nearsightedness* correction (2.0% off by more than 2 D), and additional *YAG iridotomy* (3.2%).

Only 2 eyes (0.5%) lost > 2 lines of best corrected vision (*with glasses*) compared to 6.5% of eyes that gained > 2 lines of visual acuity with glasses. Of note, only 6.5% of eyes lost 1 line of best corrected visual acuity while 38.0% of eyes gained 1 line.

Potential Complications are not limited to those reported during the clinical study. The following represent potential complications/adverse events reported in conjunction with refractive surgery in general: *conjunctival irritation, acute corneal swelling, persistent corneal swelling, endophthalmitis (total eye infection), significant glare and/or halos around lights, hyphema (blood in the eye), hypopyon (pus in the eye), eye infection, Visian ICL dislocation, macular edema, non-reactive pupil, pupillary block glaucoma, severe inflammation of the eye, iritis, uveitis, vitreous loss and corneal transplant.*

Overall, the higher the amount of nearsightedness before the Visian ICL, the higher the incidence of complications/risks after Visian ICL surgery.

## **5.0 ALTERNATIVE TREATMENTS**

- The types of eye surgeries that are available to correct nearsightedness are *Radial Keratotomy (RK), Photorefractive Keratectomy (PRK), Laser Assisted in situ Keratomileusis (LASIK)* and *Phakic Intraocular Lens* surgery. The Implantable Collamer Lens is a type of *phakic intraocular lens*. These surgeries may not meet the vision requirements for some careers, such as military service.
- Eye surgeries can be categorized by those that change the shape of the front surface of your *cornea*, which is the clear layer at the front of your eye (including *RK, PRK and LASIK*) and *intraocular lens* surgery that involves the insertion of a lens within the eye.

- RK uses a scalpel to make fine cuts in the cornea.
- PRK and LASIK use a laser to reshape the *cornea*. For LASIK, an instrument called a microkeratome first cuts a thin flap of tissue from the front of your *cornea*. This *corneal flap* is folded back and the laser removes tissue under the flap to change the shape of the front surface of your eye (*cornea*). Then the flap is put back in place for the eye to heal.

## 6.0 CONTRAINDICATIONS

You should **NOT** have *Visian ICL* surgery if you:

- Have a narrow *anterior chamber angle* as determined by a special examination by your eye doctor, or if your doctor determines that the shape of your eye is not adequate to fit the *Visian ICL* (*anterior chamber depth* less than 3 mm)
- Are pregnant or nursing
- Do **not** meet the minimum *endothelial* cell density for your age at the time of implantation as determined by your eye doctor

## 7.0 WARNINGS

- Two *iridotomies* (holes in the extreme outer edge of the colored portion of the eye) must be performed 90° apart using a yttrium aluminum garnet (YAG) laser at between 2 to 3 weeks before implantation of the *Visian ICL*.
- The long-term effects on the corneal endothelium have not been established. You should be aware of potential risk of *corneal edema* (*swelling*), possibly requiring

*corneal transplantation*. Periodic checks of your endothelium are recommended to monitor the long-term health of the cornea

- The long-term rate of cataract formation (decrease clarity of your natural crystalline lens) secondary to implantation / removal and/or replacement of the Visian ICL are unknown.
- The potential of the lens to alter the pressure in your eye and the long-term risks of *glaucoma*, *peripheral anterior synechiae* and *pigment dispersion* are unknown.

## 8.0 PRECAUTIONS

1. Patients with higher amounts of *nearsightedness* had worse results with lower effectiveness and higher risk of complications.
2. The effect of *pupil* size on visual symptoms is not known.
3. The relationship between the Visian ICL and future lens opacities and retinal detachment is undetermined.
4. There currently is a lack of long-term data to assess *cataract* formation and *cataract* progression following removal and/or replacement of the lens.
5. The effectiveness of ultraviolet absorbing lenses in reducing the incidence of *retinal* disorders has not been established.
6. The safety and effectiveness of the *Visian ICL* for the correction of moderate to high *nearsightedness* has **NOT** been established in patients:
  - with unstable or worsening *nearsightedness*
  - with history or clinical signs of *iritis/uveitis*
  - with *diabetic retinopathy*

- with *glaucoma*
- with history of previous eye surgery
- with serious (life-threatening) non-ophthalmic disease
- with progressive sight-threatening disease other than *nearsightedness*
- with a diagnosis of *ocular hypertension*(*high eye pressure*)
- with insulin-dependent diabetes
- with *pseudoexfoliation*
- with *pigment dispersion*
- with greater than -20 D of nearsightedness; greater than 2.5 D of astigmatism

## **9.0 ARE YOU A GOOD CANDIDATE FOR VISIAN ICL FOR NEARSIGHTEDNESS SURGERY?**

If you are considering Visian ICL surgery for *nearsightedness* you must:

- be between the ages of 21 and 45
- have between -3D and -20D of *nearsightedness* and no more than 2.5D of *astigmatism*
- understand that the Visian ICL is indicated for the correction of nearsightedness between -3D and  $\leq -15D$  and the reduction of nearsightedness between  $> -15D$  and -20D
- have an anterior chamber depth of 3.0 millimeters or greater
- have a minimally acceptable endothelium cell density which will be determined by your physician
- have a refraction that has been stable for at least 1 year

- understand the risks and benefits of Visian ICL for *nearsightedness* surgery compared to other available treatments for *nearsightedness*
- be able to lie flat on your back
- have no known allergies to any of the medications that your physician may discuss will be used before, during and after your surgery
- not be pregnant or nursing
- understand that prior to implantation of the *Visian ICL* you will need to undergo *YAG iridotomy* 2 to 3 weeks before *Visian ICL* surgery
- be willing to sign an Informed Consent Form provided by your doctor.

## **10.0 WHAT SHOULD YOU EXPECT DURING VISIAN ICL SURGERY?**

### **Before the Surgery**

Before surgery, your doctor needs to determine your complete medical and eye history and check the health of both your eyes. This exam will determine if your eyes are healthy and if you are a good candidate for *Visian ICL* surgery. This examination will include a measurement of the inner layer of your cornea (*endothelium*).

Tell your doctor if you take any medications, have any eye conditions, have undergone previous eye surgery, have any medical conditions or have any allergies. Ask your doctor if you should eat or drink right before the surgery. **You should also arrange for transportation since you must not drive immediately after surgery.** Your doctor will let you know when your vision is good enough to drive again.

### **Two to Three Weeks before Surgery**

Two to three weeks before your Visian ICL surgery, your eye doctor will schedule to perform *YAG laser iridotomy* to prepare your eye for implantation of the *Visian ICL*. This is necessary to make sure that the fluid flows properly from the back chamber to the front chamber of the eye to prevent a buildup of pressure within the eye after *Visian ICL* surgery. The doctor will usually apply numbing drops to the eye and make tiny openings in the colored portion of the eye with a laser beam. Usually this doesn't affect your ability to drive home after this procedure but check with your eye doctor.

After the *iridotomy* procedure, your eye doctor will prescribe eye drops for you to use. It is important that you follow-up all medication instructions. Your physician will instruct you to discontinue the use of these medications before the day of surgery.

### **The Day of Surgery**

The day of surgery, your eye doctor will place eye drops in your eye to dilate (enlarge) the *pupil* in your eye.

Once your pupil is fully dilated, your eye doctor will put numbing eye drops in your eye and/or use an injection of numbing medication and ask you to lie on your back on the treatment table/chair in the treatment room. Your eye doctor may discuss alternative anesthetic/sedation options with you before surgery.

A small incision is made into your *cornea* and the *Visian ICL* is inserted and positioned in its proper position in the eye as illustrated in Diagram 3 at the beginning of this booklet. The entire procedure will usually take approximately 20 to 30 minutes or less.

After the surgery is complete, your doctor will place some eye drops/ointment in your eye. For your eye protection and comfort, your doctor may apply a patch or shield over your eye. The procedure is painless because of the numbing medication. **It is important that you do not drive yourself home and make arrangements before the day of surgery for transportation home.**



## **The First Days after Surgery**

Your physician will need to see you the day after surgery for a check up which will include monitoring the pressure in your eye.

You may be sensitive to light and have a feeling that something is in your eye. Sunglasses may make you more comfortable. Also, your eye may hurt. Your doctor can prescribe pain medication to make you more comfortable during the first few days after the surgery. If you experience severe pain in the eye, please contact your doctor immediately. You will need to use *antibiotics* and *anti-inflammatory eye medications* (eye drops/ointments) in the first week.

**IMPORTANT:** Use the eye medications as directed by your eye doctor. (Your results may depend upon your following your doctor's instructions).

DO NOT rub your eyes especially for the first 3 to 5 days. If you notice any sudden decrease in your vision, you should contact your doctor immediately.

**Long Term Care:** In a small number of cases *Visian ICL* replacement and/or removal may become necessary. After *Visian ICL* surgery it is important that you follow your physician's recommendations for eye care and follow-up visits.

## **11.0 QUESTIONS TO ASK YOUR DOCTOR**

You may want to ask the following questions to help you decide if *Visian ICL* surgery for *nearsightedness* is right for you:

- What are my other options to correct my *nearsightedness*?
- Will I have to limit my activities after surgery and for how long?

- What are the benefits of *Visian ICL* surgery for my amount of *nearsightedness*?
- What vision can I expect in the first few months after surgery?
- If *Visian ICL* surgery does not correct my vision, what is the possibility that my eyeglasses would need to be stronger than before? Could my need for eyeglasses increase over time? Could I undergo a different type of eye surgery for the correction of my vision?
- How is *Visian ICL* surgery likely to affect my need to wear eyeglasses or contact lenses as I get older?
- Will my eye heal differently, if injured after implantation of the *Visian ICL*?
- Should I have *Visian ICL* surgery in my other eye?
- How long will I have to wait before I can have surgery in my other eye?
- What vision problems might I experience if I have an *Visian ICL* only in 1 eye?

Discuss the cost of surgery and follow-up care needs with your doctor. Most health insurance policies do not cover eye surgery for the correction of *nearsightedness*.

## 12.0 SELF-TEST

### Are You An Informed And Educated Patient?

Take the test below to see if you can answer the following questions after reading.

	<u>True</u>	<u>False</u>
1. <i>Visian ICL</i> surgery for nearsightedness is the same as laser surgery.	<input type="checkbox"/>	<input type="checkbox"/>
2. <i>Visian ICL</i> surgery is risk-free.	<input type="checkbox"/>	<input type="checkbox"/>
3. It does <u>not</u> matter if I wear my contact lenses before <i>Visian ICL</i> surgery when my doctor told me <u>not</u> to wear them.	<input type="checkbox"/>	<input type="checkbox"/>
4. After the surgery, there is a good chance that I will depend less on eyeglasses or contact lenses to see distance objects.	<input type="checkbox"/>	<input type="checkbox"/>
5. There is a risk I may lose some best corrected vision after <i>Visian ICL</i> surgery.	<input type="checkbox"/>	<input type="checkbox"/>
6. It does not matter if I am pregnant or nursing.	<input type="checkbox"/>	<input type="checkbox"/>
7. If my doctor finds that I have narrow chamber angles, I am still a good candidate for <i>Visian ICL</i> surgery.	<input type="checkbox"/>	<input type="checkbox"/>
8. The <i>Visian ICL</i> will correct my <i>astigmatism</i>	<input type="checkbox"/>	<input type="checkbox"/>
9. It is important I follow my eye doctor's specific instructions concerning medications.	<input type="checkbox"/>	<input type="checkbox"/>
10. My eye doctor does not need to know about my full medical history (conditions not dealing with the eye)	<input type="checkbox"/>	<input type="checkbox"/>

You can find the answers to Self-Test at the end of Section 13.

### 13.0 SUMMARY OF IMPORTANT INFORMATION

- *Visian ICL* Surgery provides a permanent correction of your *nearsightedness* as long as the *Visian ICL* remains in the eye. The *Visian ICL* may be removed or replaced.
- *Visian ICL* surgery does not eliminate the need for reading glasses, even if you have never worn them before.
- Your vision must be stable before *Visian ICL* surgery. You must provide written evidence that your *nearsightedness* has changed no more than 0.50 D each year for at least 1 year.
- Pregnant and nursing women should wait until they are not pregnant and not nursing to have the *Visian ICL* surgery.
- *Visian ICL* surgery has some risks. Please read and understand this entire booklet before you agree to the surgery. The sections on Benefits and Risks are especially important to read carefully.
- Some other options to correct *nearsightedness* include glasses, contact lenses, *RK*, *PRK* and *LASIK*.
- Before considering *Visian ICL* surgery you should:
  - a. have a complete eye examination.
  - b. talk with at least one eye care professional about *Visian ICL* surgery, especially the potential benefits, risks, and complications. You should discuss the time needed for healing after surgery.

- Certain eye diseases, eye conditions, previous eye surgery, systemic medical conditions may have an impact on the results after *Visian ICL* surgery. It is important that you provide your eye doctor with your complete medical history so your eye doctor may determine if you are a good candidate for the *Visian ICL* for correction of nearsightedness.
- The *Visian ICL* is intended to improve your vision. However, because you are a *nearsighted* patient you should consult with your eye doctor on a regular basis (i.e., once a year) to verify the overall health of your eye.

#### Answers to Self-Test Questions:

- |      |       |
|------|-------|
| 1. F | 6. F  |
| 2. F | 7. F  |
| 3. F | 8. F  |
| 4. T | 9. T  |
| 5. T | 10. F |

## 14.0 GLOSSARY

This section summarizes important terms used in this information booklet or that your eye doctor may discuss with you. Please discuss any related questions with your doctor.

**Acute:** Of sudden, rapid onset, usually with notable symptoms.

**Acute Corneal Decompensation:** A sudden opacification (clouding) of the usually clear front surface of the eye (cornea).

**Anterior Capsule:** The front surface of the crystalline lens. It is a thin layer of skin totally surrounding the lens much like the skin of a grape.

**Anterior Chamber:** Front chamber of the eye; anterior chamber depth is the thickness of the chamber

**Antibiotic Medication:** A drug used to treat or prevent infection. Your doctor may prescribe this medication after Visian ICL surgery.

**Anti-inflammatory Medication:** A drug that reduces inflammation or the body's reaction to injury or disease. Any eye surgery can cause inflammation. Your doctor may prescribe the medication after Visian ICL surgery.

**Astigmatic Keratotomy:** A type of eye surgery that changes the shape of the front surface of the eye by making a special pattern of cuts in the cornea to correct astigmatism.

**Astigmatism:** A focusing error that results in blurred distant and/or near vision. The cornea is more curved in some directions than others, and causes light rays to focus at different points inside the eye. Parts of objects appear clearer than other parts.

**Best Corrected Vision:** Best vision when wearing eyeglasses.

**Cataract:** Opacity, or clouding, of the crystalline lens inside the eye that can blur vision.

**Collagen:** A gel-like supporting substance found in the cornea, skin and other connective tissue of the body.

**Collamer:** Hydroxyethyl methacrylate (HEMA)/porcine-collagen based polymer material (STAAR proprietary product).

**Implantable Collamer Lens (ICL):** A collagen based contact lens which is implanted permanently in the rear chamber of the eye immediately in front of the crystalline lens in order to correct nearsightedness. The Visian ICL can be replaced or removed.

**Conjunctival Irritation:** A reddening of the observable, white portion of the eyeball and inner eyelid.

**Contraindications:** Any special conditions that result in the treatment not being recommended.

**Contrast Sensitivity:** A measure of the ability of the eye to detect small lightness differences between objects and the background in daylight and in dim light. For example, black lines on a gray background are easier to see than gray lines on a gray background. Objects in daylight are also easier to see than in dim light. Contrast sensitivity is a way to determine how well patients can see in poor contrast conditions such as very dim light, rain, snow and fog.

**Cornea:** The clear front layer of the eye. Surgery such as PRK, LASIK and RK reshapes the front surface of the cornea to improve distant vision.

**Corneal Swelling:** Abnormal fluid build-up/swelling in the cornea. The condition is usually temporary after surgery with no significant effect on vision. Persistent corneal swelling may cause a loss of vision.

**Corneal Flap:** A thin slice of tissue on the surface of the cornea made with a microkeratome at the beginning of a LASIK procedure. This flap is folded back before the laser shapes the inner layer of the cornea.

**Corneal Transplant:** Removal and replacement of cornea

**Crystalline Lens:** A structure inside the eye that helps to focus light onto the back surface (retina) of the eye.

**Diabetic Retinopathy:** Damage to the back surface of the eye responsible for sensing light due to diabetes.

**Diopter:** A unit of focusing power, used to describe the amount of nearsightedness and astigmatism of an eye. Abbreviated as “D”.

**Double Vision:** Seeing multiple images of the object being looked at.

**Endophthalmitis:** Severe infection or inflammation of the entire eyeball.

**Endothelium:** Inner layer of the cornea.

**Endothelial Cell Loss:** Loss of cells in the endothelium. Endothelial cells are essential in keeping the cornea clear and are essential for maintenance of good vision.

**Excimer Laser:** A type of laser used in LASIK and PRK to remove tissue from the cornea.

**Glare:** A harsh or uncomfortable bright light. Glare symptoms are usually caused by a distortion of light that would otherwise be tolerable without the distortion.

**Glaucoma:** An eye disease usually associated with high eye pressure. Glaucoma damages the optic nerve of the eye and usually causes a progressive loss of vision.

**Halos:** Circular flares or rings of light that may appear around a headlight or other lighted object. This symptom may occur after surgery.

**Hyphema:** Blood in the anterior chamber of the eye.

**Hypopyon:** Pus in the front chamber of the eye.

**ICL:** Implantable Collamer Lens (see Device Description Section of this Booklet)



**Inflammation of the Eye:** The eye's response to injury, infection or irritation which can cause redness of the eye, pain, blurred vision and/or light sensitivity.

**Intraocular Lenses:** A lens that is placed in the eye after extraction of a cataract and removal of the crystalline lens.

**Intraocular Pressure (IOP):** Pressure measurement monitored in your eye.

**Iris:** Colored part of the eye.

**Iris Prolapse:** A movement of the colored portion of the eye through a surgical wound to a position outside the eye.

**Iritis/Uveitis:** Inflammation in the anterior chamber or other portion of the eye.

**Laser Assisted In-Situ Keratomileusis (LASIK):** A type of eye surgery that uses a microkeratome and a laser to improve vision. The microkeratome creates a thin, hinged flap of tissue on the cornea which is then folded back. The laser shapes the tissue under the flap and the flap is put back on the eye so the tissue heals.

**Lens:** Natural crystalline lens in the eye which helps focus light properly into the back of the eye.

**Lens Opacities:** A cloudiness of the crystalline lens.

**Lens Dislocation:** A movement of the lens to an improper position.

**Macular Edema:** Swelling in the area responsible for fine (reading) vision on the back surface of the eye (retina).

**Macular Hemorrhage:** Bleeding in the area responsible for fine (reading) vision on the back surface of the eye (retina).

**Manifest Refraction Spherical Equivalent (MRSE):** A routine examination of the eye to evaluate the amount of refractive error (i.e., amount of nearsightedness; amount of astigmatism). Information used to prepare eyeglass/contact lens prescriptions.

**Microkeratome:** A surgical instrument used in LASIK to cut a thin flap of tissue from the front surface of the eye (cornea) before the laser treatment is applied.

**Myopia:** A focusing error that results in blurrier vision at distance than near. Myopia is also called nearsightedness.

**Narrow Anterior Chamber Angle:** A decrease in the size of the front chamber of the eye which could block the flow of fluid from inside to outside of the eye resulting in a raised eye pressure (glaucoma).

**Nearsighted/Nearsightedness:** A focusing error that results in blurrier vision at distance than near. Nearsightedness is also called myopia.

**Non-reactive Pupil:** A condition where the colored portion of the eye does not get larger or smaller when light is shined in the eye or removed.

**Ocular Hypertension:** Increased eye pressure.

**Peripheral Iridectomy:** A small hole placed at the outer edge of the colored portion of the eye.

**Persistent:** Lasts for a period of time during the study follow-up usually at least until the end of the study.

**Phakic Intraocular Lens:** Placement of a man-made lens in a patient who still has their natural crystalline lens.

**Photorefractive Keratectomy (PRK):** A type of eye surgery that uses an excimer laser to reshape the front surface of the eye to improve vision. After the epithelium (outermost layer) of the cornea is first scraped away, the laser removes tissue from the exposed surface. After the surgery, the epithelium grows back.

**Peripheral Anterior Synechiae:** Scar tissue at the outer edges of the front chamber of the eye.

**Pigment Dispersion:** An abnormal release of pigment particles from cells in the eye that could get trapped in the fluid filtering mechanism (trabecular meshwork) possibly causing an increase in pressure in the eye (glaucoma).

**Posterior Chamber:** Back or rear chamber of the eye.

**Pseudoexfoliation:** A condition where flakes of material can come off the surface of the crystalline lens and block the drainage of fluid from the inside to the outside of the eye.

**Pupil:** The black part of the eye; fluctuates in size allowing varying degrees of light into the eye.

**Pupillary Block Glaucoma:** The inability of fluid to flow from the back chamber of the eye to the front chamber frequently blocking drainage of fluid out of the eye and raising the pressure in the eye (glaucoma).

**Radial Keratotomy (RK):** A type of eye surgery that changes the shape of the front surface of the eye by making a special pattern of cuts in the cornea to correct nearsightedness.

**Retina:** The layer of nerve tissue at the back of the eye that captures images, similar to film in a camera, and sends information about these images to the brain. Light must be focused correctly on the retina to form clear images.

**Retinal Detachment:** Separation of the retina from the rest of the back surface of the eyeball.

**Shallow Anterior Chamber:** A flattening of the front chamber of the eye.

**Subretinal Hemorrhage:** Bleeding under the retina (see retina above).

**Uveitis:** Pathologic condition. Inflammation of any of the structures of the uvea: iris, ciliary body, or choroid.

**Visian ICL:** Implantable Collamer Lens for the correction of nearsightedness (see Device Description Section of this Booklet).

**Visual Acuity:** A measure of the sharpness of vision using a letter chart. Best Corrected Visual Acuity (best vision with eyeglasses). Uncorrected Visual Acuity (best vision without eyeglasses or contact lenses).

**Vitreous Loss:** The loss of a clear gel like material from the farthest back chamber of the eye during a surgical procedure.

**YAG Laser: (Yttrium Aluminum Garnet) Laser Iridotomy:** Production of a small hole in the colored portion of the eye using a laser beam.

## **15.0 PATIENT ASSISTANCE INFORMATION**

To be completed by you or your Primary Eye Care Professional as a reference.

Primary Eye Care Professional

Name: \_\_\_\_\_

Address: \_\_\_\_\_

Phone: \_\_\_\_\_

Visian ICL Doctor

Name: \_\_\_\_\_

Address: \_\_\_\_\_

Phone: \_\_\_\_\_

Treatment Location

Name: \_\_\_\_\_

Address: \_\_\_\_\_

Phone: \_\_\_\_\_

Visian ICL Manufacturer:

STAAR Surgical, AG Hauptstrasse 104 CH-2560 Nidau, Switzerland Tel: + (41) 32 332 8888 FAX: + (41) 32 332 8899
--

U.S. Distributor:

STAAR Surgical Company 1911 Walker Avenue Monrovia, CA 91016 USA  Tel: (800) 352-7842 FAX: (800) 952-4923
--

*Patient Information Sheet*  
**Visian ICL™ (Implantable Collamer Lens) for**  
*Nearsightedness (Myopia)*

**IMPORTANT:**The following basic information about the Visian Implantable Collamer Lens (ICL) is provided for you by STAAR Surgical Company.

**If you are interested in the Visian ICL, please see a licensed eye care professional. Based on your individual needs, your eye care professional will determine if the Visian ICL is right for you. The Visian ICL is implanted by an ophthalmic surgeon and therefore you will need to make arrangements to meet with an ophthalmic surgeon experienced with the Visian ICL.**

**What is the Visian ICL for Nearsightedness?**

The Implantable Collamer Lens for Nearsightedness is a refractive lens also known as a phakic IOL. “Phakic” meaning that the natural lens of the eye is in place, and “IOL” meaning intraocular lens, or a lens inside the eye. The Visian ICL is a posterior chamber implant that is situated through a small incision in the eye behind the iris (the colored part of the eye), and in front of the natural crystalline lens in order to improve your nearsightedness.

**What are Visian ICL’s made of?**

The material is called Collamer®, a collagen co-polymer that contains a small amount of purified collagen which is proprietary to STAAR Surgical; the remainder is made of a similar material to that found in soft contact lenses. It is very biocompatible (does not cause a reaction inside the eye) and stable. It also contains an ultraviolet light filter.

**What is the Visian ICL intended for?**

The Visian ICL is designed for the correction of moderate to high nearsightedness (-3.0 to -15.0 diopters (D)), and the reduction of nearsightedness in patients with up to -20 diopters (D) of nearsightedness. It is indicated for patients who are at least 21 years of age. In order to be sure that your surgeon will use an Visian ICL with the most adequate power for your eye, your nearsightedness should be stable for at least a year before undergoing eye surgery.

The Visian ICL represents an alternative to other refractive surgeries including laser assisted in situ keratomileusis (LASIK), photorefractive keratectomy (PRK), incisional surgeries, or other means to correct myopia such as contact lenses and eye glasses.

The Visian ICL is not intended to correct any astigmatism you may have.

**Who should not have Visian ICL surgery?**

Patients who are pregnant and nursing and patients with a narrow angle in the front chamber of their eye, because in this case the space for the Visian ICL would be too small. The patient education booklet provides an additional list of conditions that should be taken into consideration when making a decision about the Visian ICL.

**What is the key potential benefit of the Visian ICL?**

The key benefit of Visian ICL surgery is the permanent correction or reduction of your nearsightedness allowing you to see clearly at long distances without eyeglasses or contact lenses or reduce your dependence upon them. In addition to the improvement of your uncorrected vision (vision without eyeglasses or contact lenses), your best corrected vision (best vision with contact lenses/eye glasses) may be improved.

**What are the potential risks of the Visian ICL for Nearsightedness?**

Early complications reported the first week after Visian ICL surgery include: Visian ICL removal and reinsertion at the time of initial surgery, shallowness of the front chamber of the eye that can create an increase of the pressure into your eye and may necessitate a peripheral iridectomy (a procedure where a small hole is placed in iris (colored part of eye) using a laser called “YAG laser), temporary corneal swelling (edema) and transient inflammation in the eye or iritis.

Complications after 1 week include: increase in astigmatism, loss of best corrected vision, clouding of the Crystalline lens (cataract), loss of cells from the back surface of the cornea responsible for the cornea remaining clear (endothelial cell loss), increase in eye pressure, iris prolapse, cloudy areas on the

crystalline lens that may or may not cause visual symptoms (crystalline lens opacities), macular hemorrhage, subretinal hemorrhage, retinal detachment, secondary Visian ICL related surgeries (replacements, repositionings, removals, removals with cataract extraction), too much or too little nearsightedness correction, and additional YAG iridotomy necessary.

**What are risks of Refractive Eye Surgery in general?**

Potential complications for refractive surgery in general include: irritation of the conjunctiva (white part of eye), corneal swelling (outer layer of eye), eye infection, significant glare and/or halos around lights, blood/pus in the eye, lens dislocation, macular edema, (swelling in back of the eye), non-reactive pupil, pupillary block glaucoma resulting in raised eye pressure, irritation of the iris (colored part of the eye), severe inflammation of the eye and loss of the vitreous (gel in back of eye).

**You should carefully review all benefits and risks of Visian ICL surgery with your eye care professional before making a decision about the Visian ICL.**

**What is involved in the Visian ICL procedure?**

The Visian ICL surgery is performed on an outpatient basis which means that the patient has surgery and leaves the same day. The patient will need someone to drive them home on surgery day. A light, topical or local anesthetic is administered. There is very little discomfort during or after surgery. Some eye drops or medication may be prescribed and a visit with your eye care professional is usually scheduled the day after surgery.

**Can the Visian ICL be felt once it is in place?**

The Visian ICL is not typically noticeable after it is implanted. It does not attach to any structures within the eye and does not move around once in place.

**Can the Visian ICL be removed?**

The Visian ICL is intended to remain in place without maintenance. The Visian ICL can be removed or replaced by your eye care professional if needed in the future, with or without replacing it depending on your eye condition. If your physician deems the Visian ICL cannot be replaced, you will lose the benefit of your nearsightedness correction.

**What are the key points to remember?**

Follow all of your eye care professional's instructions before and after implantation of the Visian ICL. Take any prescribed medication and schedule all recommended follow-up visits with your eye care professional, usually on an annual basis after the healing of the Visian ICL surgery. Contact your eye care professional immediately if you should experience a problem.

**What if I have more questions regarding the Visian ICL for Nearsightedness?**

It is crucial you visit your eye care professional about your eye health and to obtain complete information concerning the Visian ICL procedure. Please discuss all your questions with your eye care professional.

**If you want to read more about the Visian ICL for Nearsightedness, ask your eye care professional for the patient education booklet available from STAAR Surgical or the package insert written for the eye care professional.**

**For more information call (800) 352-7842 or visit our website at [www.staar.com](http://www.staar.com).**

**The Visian ICL is:**

**Distributed by:**

**STAAR Surgical Company  
1911 Walker Avenue  
Monrovia, CA 91016 USA  
Tel: (800) 352-7842  
Fax: (800) 952-4923**

**Manufactured by:**

**STAAR Surgical AG  
Hauptstrasse 104  
CH2560 Nidau, Switzerland  
Tel: +(41) 32 332 8888 Fax: +(41) 32 332 8899**